



## CARATTERISTICHE

1) Sistema per porte pieghevoli a 180 gradi

2) Materiale braccio e fulcri in INOX AISI 304

## ISTRUZIONI PER IL MONTAGGIO

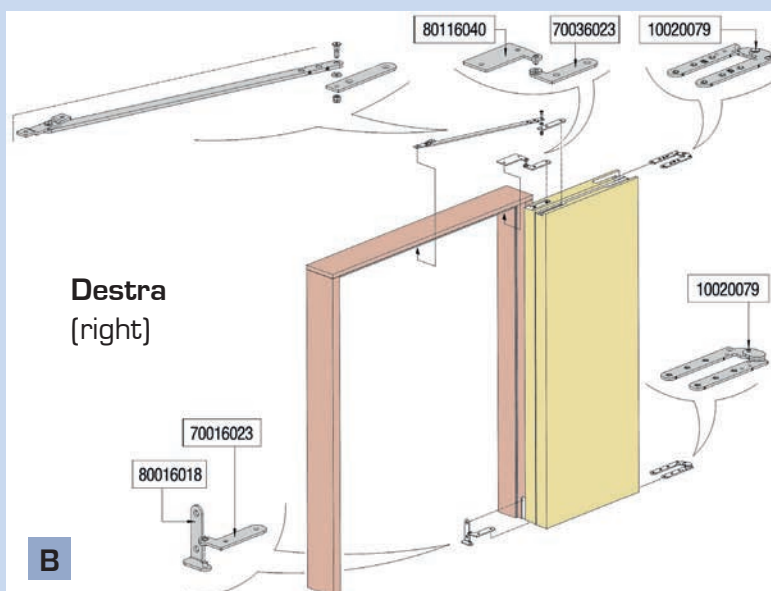
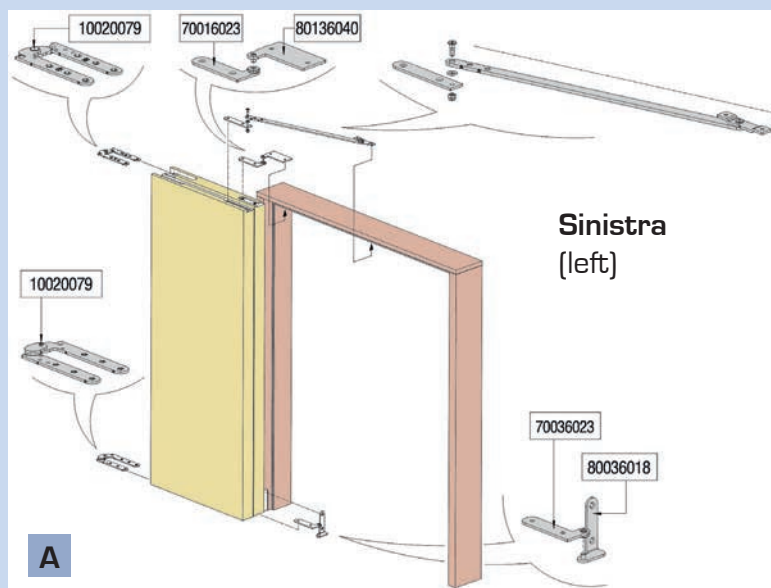

PORTA mm 600/650/700 Dx  
CODICE 87788067DX

PORTA mm 600/650/700 Sx  
CODICE 87788067SX

PORTA mm 700/750/800 Dx  
CODICE 87788078DX

PORTA mm 700/750/800 Sx  
CODICE 87788078SX

PORTA mm 800/850/900 Dx  
CODICE 87788089DX

PORTA mm 800/850/900 Sx  
CODICE 87788089SX

PORTA mm 900/950/1000 Dx  
CODICE 87788090DX

PORTA mm 900/950/1000 Sx  
CODICE 87788090SX

PORTA mm 1000/1050/1100 Dx  
CODICE 877880110DX

PORTA mm 1000/1050/1100 Sx  
CODICE 877880110SX

**Braccio con fulcro e piastra inox**

<b>MM 372</b>	CODICE 87520067
<b>MM 422</b>	CODICE 87520078
<b>MM 472</b>	CODICE 87520089
<b>MM 522</b>	CODICE 87520090
<b>MM 572</b>	CODICE 87520110



**Fulcro inox superiore destro**

CODICE 80116040



**Fulcro inox superiore sinistro**

CODICE 80136040

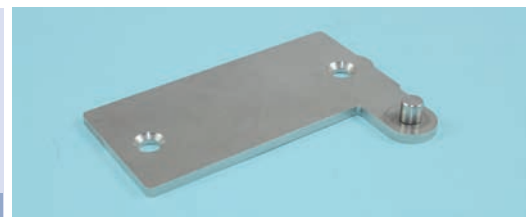

**Fulcro inox inferiore destro**

CODICE 80016018



**Fulcro inox inferiore sinistro**

CODICE 80036018



**Cerniera fulcro inox inferiore destra  
superiore sinistra**

CODICE 70016023



**Cerniera fulcro inox inferiore sinistra  
superiore destra**

CODICE 70036023



**Cerniera Sirio zancata cromo satinata**

CODICE 10020079



## ISTRUZIONI PER IL MONTAGGIO

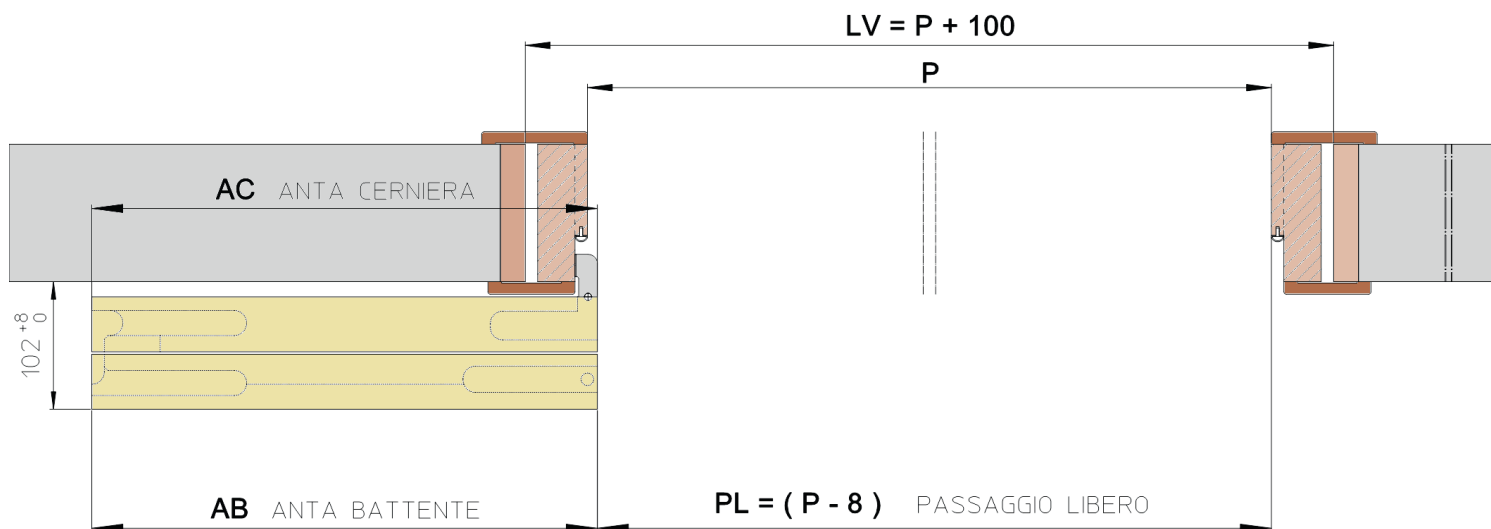

P	LV	PL	AC	AB	BRACCIO (mm)	ROMBO SX	ROMBO DX
600	700	592	306,5	306,5	372	87788067SX	87788067DX
650	750	642	331,5	331,5	372	87788067SX	87788067DX
700	800	692	356,5	356,5	372 / 422	87788067SX 87788078SX	87788067DX 87788078DX
750	850	742	381,5	381,5	422	87788078SX	87788078DX
800	900	792	406,5	406,5	422 / 472	87788078SX 87788089SX	87788078DX 87788089DX
850	950	842	431,5	431,5	472	87788089SX	87788089DX
900	1000	892	456,5	456,5	472 / 522	87788089SX 87788090SX	87788089DX 87788090DX
950	1050	942	481,5	481,5	522	87788090SX	87788090DX
1000	1100	992	506,5	506,5	522 / 572	87788090SX 877880110SX	87788090DX 877880110DX
1050	1150	1042	531,5	531,5	572	877880110SX	877880110DX
1100	1200	1092	556,5	556,5	572	877880110SX	877880110DX

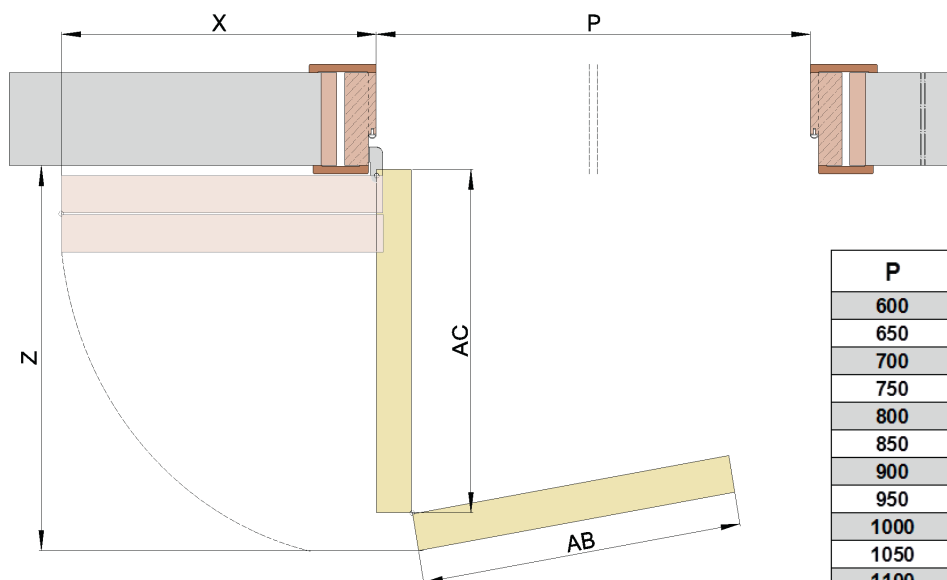

P	AC	AB	X	Z
600	306,5	306,5	298,5	356
650	331,5	331,5	323,5	381
700	356,5	356,5	348,5	406
750	381,5	381,5	373,5	431
800	406,5	406,5	398,5	456
850	431,5	431,5	423,5	481
900	456,5	456,5	448,5	506
950	481,5	481,5	473,5	531
1000	506,5	506,5	498,5	556
1050	531,5	531,5	523,5	581
1100	556,5	556,5	548,5	606

## ISTRUZIONI PER IL MONTAGGIO

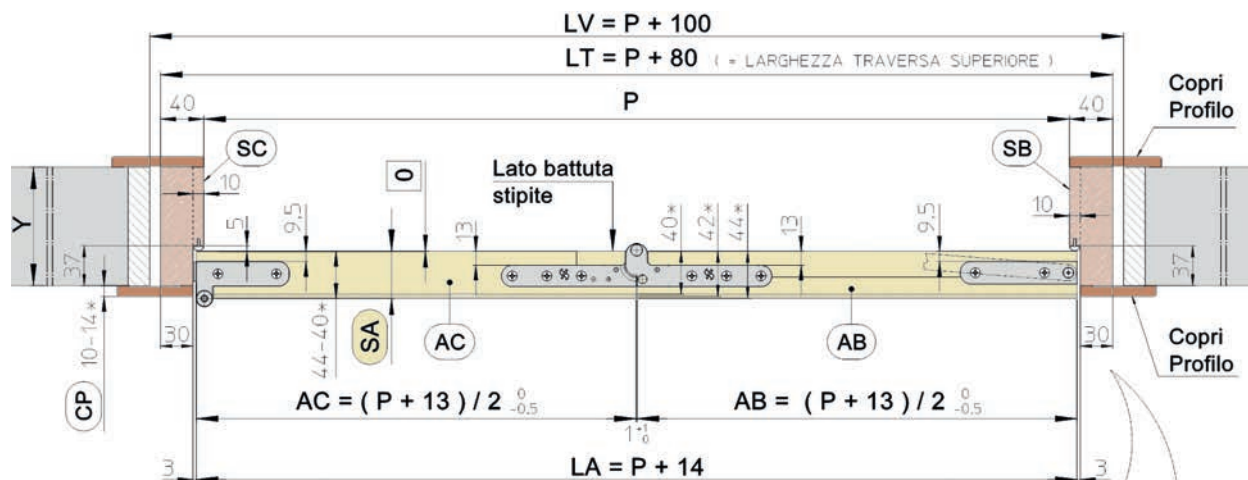

(\*) Rapporto tra spessore Anta e Copri profilo

Spessore Anta ( SA )	Spessore Copri profilo ( CP )
44	10
42	10 ÷ 12
40	10 ÷ 14

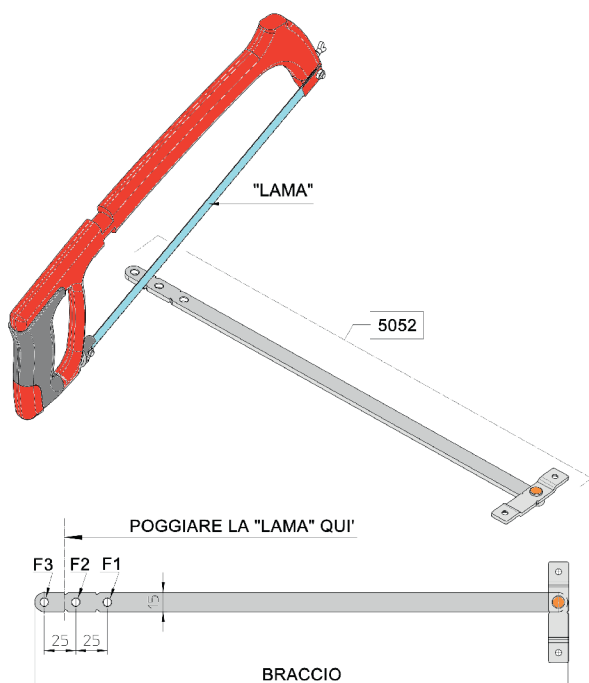
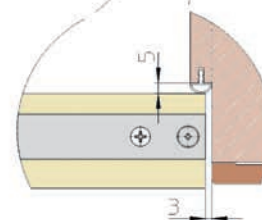

BRACCIO (mm)	( F1 )	( F2 )	( F3 )	CODICE
	P	P	P	
372	600			87520067
372		650		87520067
372			700	87520067
422	700			87520078
422		750		87520078
422			800	87520078
472	800			87520089
472		850		87520089
472			900	87520089
522	900			87520090
522		950		87520090
522			1000	87520090
572	1000			87520110
572		1050		87520110
572			1100	87520110